

Umlenker

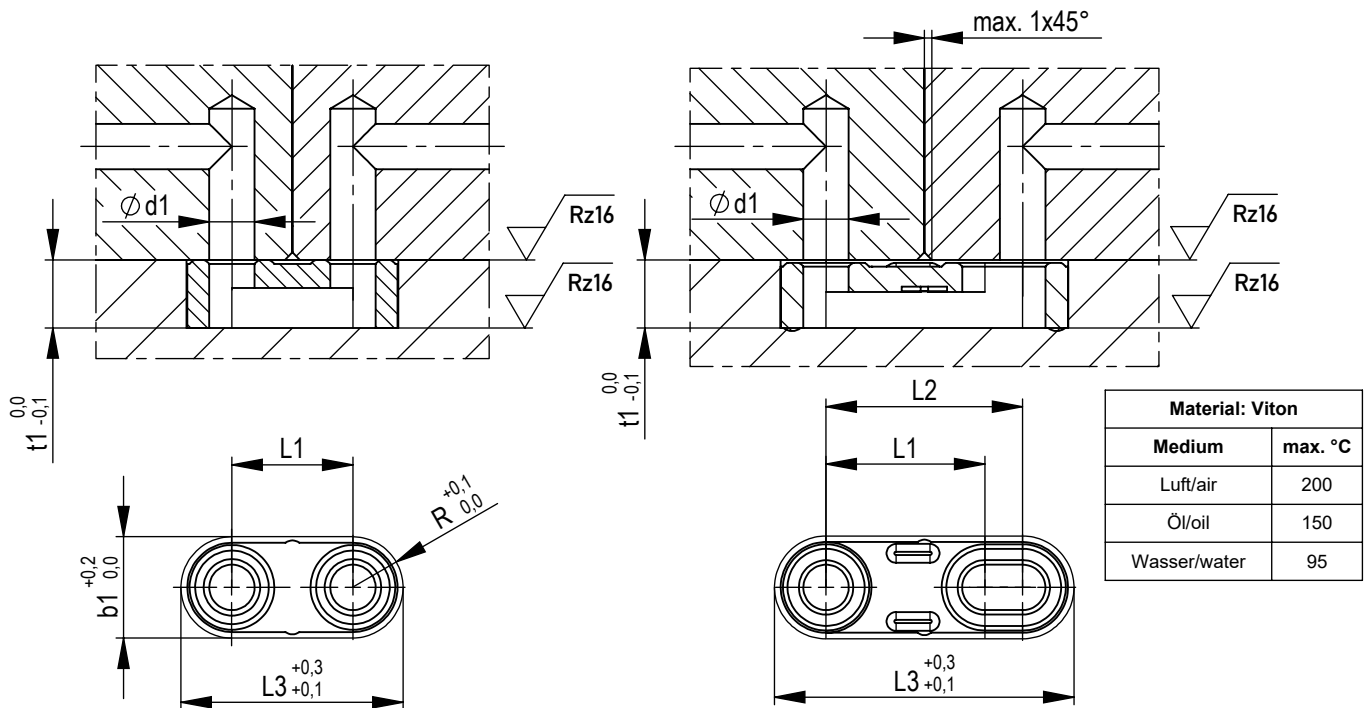

d	L1	L2	L3	b1	t1	Best.-Nr.
6	16		28	12	9	UM6x16
8	18		32	14	11	UM8x18
10	20		36	16	12	UM10x20
12	22		40	18	15	UM12x22



d	L1	L2	L3	b1	t1	Best.-Nr.
6	21	26	38	12	9	UML6x16x26
8	26	30	44	14	11	UML8x26x30
10	28	34	50	16	12	UML10x28x34
12	32	38	56	18	15	UML12x32x38

Umlenker

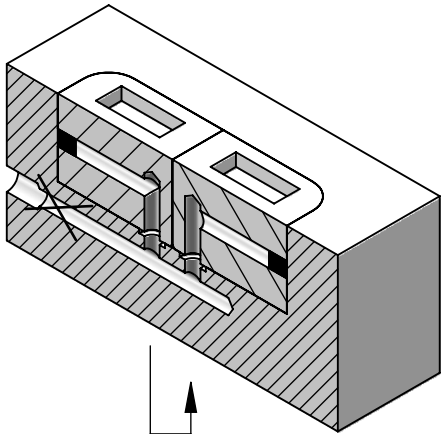

herkömmlich

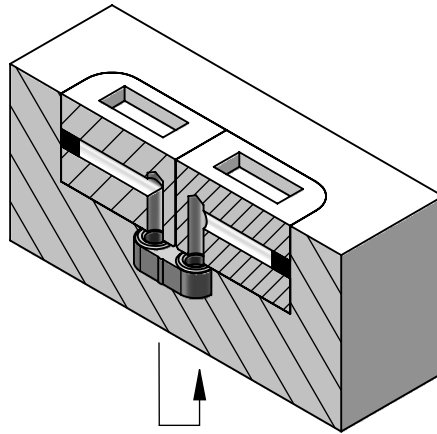

Umwege und problematische Hilfsbohrungen sind überflüssig

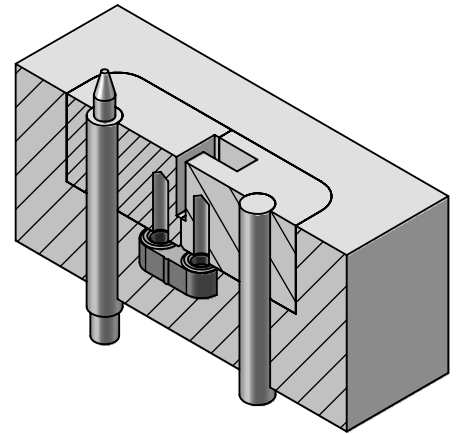

Umlenkung auch zwischen Hindernissen möglich

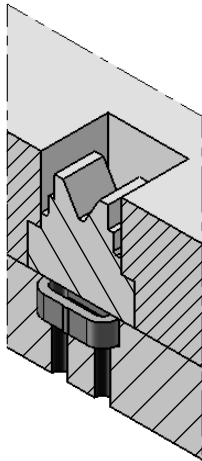

optimale Temperaturregelung von kleinsten Formeinsätzen

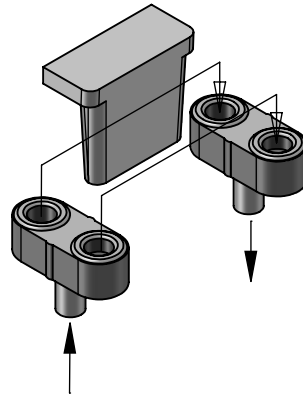

kühlen von Rippen

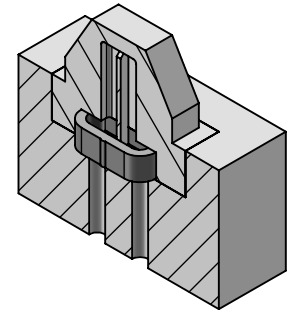

Trennblech nur im Einsatz

